

Model Number	Nominal Size (Inches) W x H x D	Actual Size (Inches) W x H x D	Rated Air Flow (CFM)	Initial Resistance (In. W.G.)	MERV	Media Area (Square Feet)
DHC95	24 x 24 x 12	23-3/8 x 23-3/8 x 11-1/2	2000	0.54	15	47
DHC95	20 x 24 x 12	19-3/8 x 23-3/8 x 11-1/2	1600	0.54	15	40
DHC95	20 x 24 x 12	19-3/8 x 19-3/8 x 11-1/2	1400	0.54	15	32
DHC95	12 x 24 x 12	11-3/8 x 23-3/8 x 11-1/2	1000	0.54	15	23
DHC85	24 x 24 x 12	23-3/8 x 23-3/8 x 11-1/2	2000	0.51	14	47
DHC85	20 x 24 x 12	19-3/8 x 23-3/8 x 11-1/2	1600	0.51	14	40
DHC85	20 x 24 x 12	19-3/8 x 19-3/8 x 11-1/2	1400	0.51	14	32
DHC85	12 x 24 x 12	11-3/8 x 23-3/8 x 11-1/2	1000	0.51	14	23
DHC70	24 x 24 x 12	23-3/8 x 23-3/8 x 11-1/2	2000	0.24	13	47
DHC70	20 x 24 x 12	19-3/8 x 23-3/8 x 11-1/2	1600	0.24	13	40
DHC70	20 x 24 x 12	19-3/8 x 19-3/8 x 11-1/2	1400	0.24	13	32
DHC70	12 x 24 x 12	11-3/8 x 23-3/8 x 11-1/2	1000	0.24	13	23

**STANDARD CONSTRUCTION**

1. High Efficiency Synthetic Filter Media
2. Expanded Metal Pleat Supports
3. Adhesive Seal on All Four Media Pack Sides
4. 24 Gauge Galvanized Steel Cell Sides
5. Plastic Fingers Maintain Pleat Spacing
6. Diagonal Support Braces on Air Entering and Air Leaving Sides for Additional Rigidity
7. 13/16" Header on Air Entering Side Standard
8. 1-1/8" 'C' Style Header Optional  
(Note 'C' in Model Number as Shown: DHC95C 24 X 24 x 12)

**NOTES**

1. MERV per ASHRAE 52.2-2007  
Tested at 492 FPM on 24x24x12 Face Size
2. Final Resistance: 1.5" W.G.
3. Rated Velocity - 500 FPM
4. Classified per U.L. Standard 900 for Flammability
6. Maximum Operating Temperature: 180 deg. F
7. Optional Gasket Available, note in the model number  
U - Upstream Gasket (Ex: DC95-U 24x24x12)  
D - Downstream Gasket  
UD - Both Sides  
SA - Side Access
8. Special Sizes Not Available

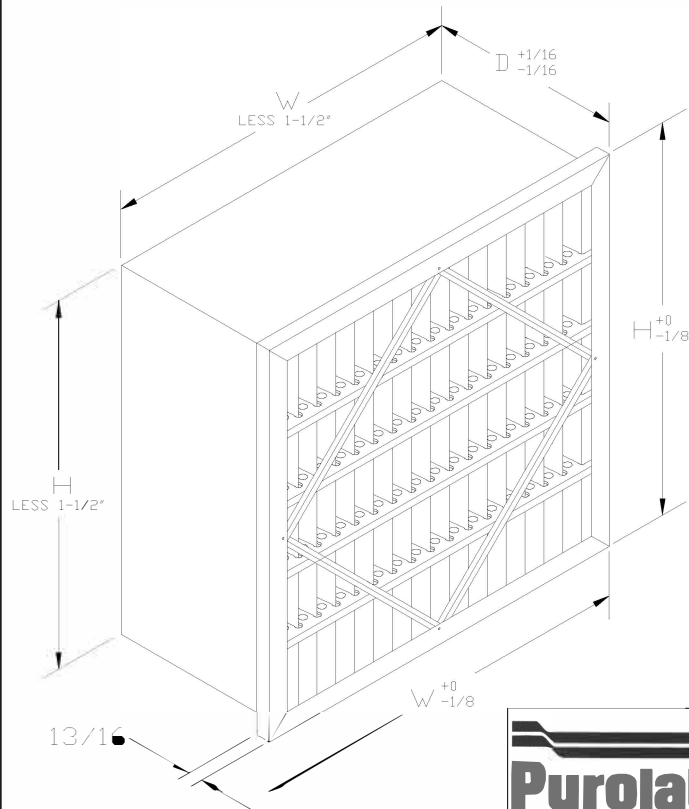

**Purolator**  
Air Cleaning Specialists  
11088 Gravois Industrial Ct.  
St. Louis, MO 63128  
(866) 455-2128  
purolatorfilters.com

**CONTACT FACTORY TO  
VERIFY REVISION LEVEL**

**TOLERANCES  
UNLESS OTHERWISE SPECIFIED**

FRACTIONAL -  
DECIMAL -  
ANGLES -

ALL DIMENSIONS IN INCHES

DRAWING NAME

**DEFIANT CELL 12" SINGLE HEADER**

APPROVED BY

*H. Quinn*

SPECIFICATION NO.

**MKT-P-00516**

PAGE

**1 OF 1**

SCALE

**NONE**

DWG. SIZE

**A**

REVISION

**A**

REVISION DATE

**08-07-12**

CONFIDENTIAL - DO NOT COPY. THIS MATERIAL IS TRADE SECRET AND PROPRIETARY BEING EXCLUSIVELY OWNED BY CLC AIR. THE EXPRESSION OF THE INFORMATION CONTAINED HEREIN IS PROTECTED UNDER FEDERAL COPYRIGHT LAWS AND ALL COPYING IS PROHIBITED AND MAY BE SUBJECT TO CRIMINAL PENALTIES.